



DIRECTIONAL LEDS



ED3801 & ED3802 SERIES

Single-, Dual- or Tri-Color Surface Mount

ED3801 and ED3802 directional LEDs are bright and versatile warning lights suited to a wide variety of applications. Their ultra-low profile makes them easy to install virtually anywhere on a vehicle and are 25% thinner than previous models. All models offer wide angle optics and multiple flash patterns, including synchronization with other units for simultaneous or alternating operation. Each LED color can be controlled independently.

Models

PART NO.	TYPE	ILLUMINATION COLOR OPTIONS	AMPS
ED3801X	Single	A B G R W	0.76
ED3802XX	Dual	AB AW AG AR BW RB RW	0.73
ED3802XXX	Tri	AGW BAW RAW RBA RBW	0.88

Replace "X" in part number with desired color: A=amber, B=blue, G=green, R=red, W=white

Design Features

- 12-24 VDC
- 25% thinner than previous models
- High-intensity LEDs provide exceptional warning
- Ultra low-profile surface mount
- Synchronizable
- Die-cast base with polycarbonate lens
- Temperature Range: -22°F to +122°F (-30°C to +50°C)

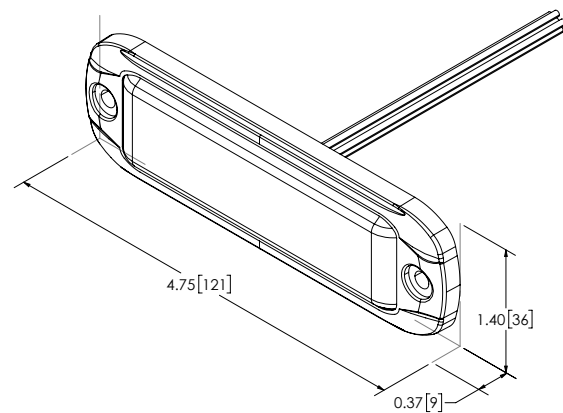

Accessories

- Black Bezel (EZ3801BKBZ)
- Chrome Bezel (EZ3801CHBZ)

